

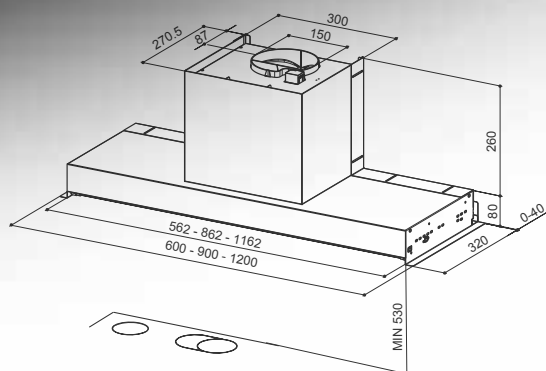





The glass visor protects the cabinets from grease vapour and steam.



IN-NOVA SMART PLUS

IN-NOVA SMART PLUS X A60 cod. 305.0557.680
 IN-NOVA SMART PLUS X A90 cod. 305.0557.691
 IN-NOVA SMART PLUS X A120 cod. 305.0554.567



FEATURES	PERFORMANCE	ACCESSORIES
Finish · Stainless steel	Speed 1 2 3	Cod. 112.0067.944
Controls Pull out Knob	Air capacity IEC point 220 325 390	F3 Charcoal filter
Lighting 2 LED lights	Pressure 160 190 200	Cod. 112.0544.470
Grease filter Stainless steel cassettes dishwasher safe	Input 85 110 145	FLL3 Charcoal filter Long Lasting
Ø of air outlet 150 / 120 mm	Noise level 55 64 69	
Width 600 / 900 / 1200 mm	INSTALLATION REQUIREMENTS	
Energy class D	Max Load 147W	Max Width of Hob 60/90/120cm
	 147W	 60/90/120cm
	Min Height	
	 53cm above a Gas Hob	 47cm above an Electric Hob